



MTB 7080 Hoist and Sub Frame

Install and Operational Manual

Installing MTB hoist on Chassis truck

1. Attach subframe and hoist combo to the truck frame see drawing on page 2.
2. connect the power and ground wire to the battery an install a 300 AMP fuse less than 18" from battery, see Battery Cable Gauge table for proper gauge and wiring diagram (pg. 3).
3. Set on the bed on subframe, position the rear hinge brackets against the long rails. Once in position, bolt the rear hinge brackets to the body Long Rails. Slide each of the lifting shafts all the way against the inside of the long beam. Bolt the lifting shaft plate to secure the shaft to the long Rail. With the shaft secured, slide the lock collars against the hoist lifting tube and lock them there by tightening the set screw. With the hoist and body completely installed, cycle the hoist several times to rid the hydraulic system of air. **WARNING:** If it is necessary to work on the hoist or body while in the raised position, **ALWAYS** block the unloaded body up securely with the body prop or body props.
4. The hydraulic pump reservoir has been filled at the factory. If more fluid is necessary use **recommended hydraulic fluid** (See Page 3). **CAUTION:** Do not overfill. Adding too much fluid will cause the reservoir to overflow when the bed is lowered. The hydraulic fluid should always be 1" from top of reservoir when cylinder is collapsed. Leave the breather off and fully lower the bed to the down position. The bed can then be raised, and the breather reinstalled. The reason for leaving the breather off during the first cycle after filling it is to guard against pressurizing the reservoir in the event that it has been overfilled. Back pressure due to overfilling may dislodge the reservoir from the pump. Adding too much fluid will result in the reservoir overflowing when the bed is lowered.
5. Install the remote control in the cab, unplug it from the power unit and route the end of the cable through the floor of the pickup cab behind the driver's seat (preferably through a rubber plug in the floor). The cable should then be routed up the back of the cab, to the power unit where it should be reconnected.
6. 9. The MTB Hoist has been designed for use with most 60 & 84 CA chassis trucks. **Never exceed the manufacturer's gross vehicle rating of the truck.** These ratings can usually be found on the end of door just above or below the latch on the driver's side. Filling the bed without regard to the weight of the material being loaded can result in structural failure and injury. Never exceed the Hoist and trucks maximum ratings. The MTB 7080 Hoist and subframe combo unit has a maximum load capacity of 7000-8000 LBS.

Install drawing

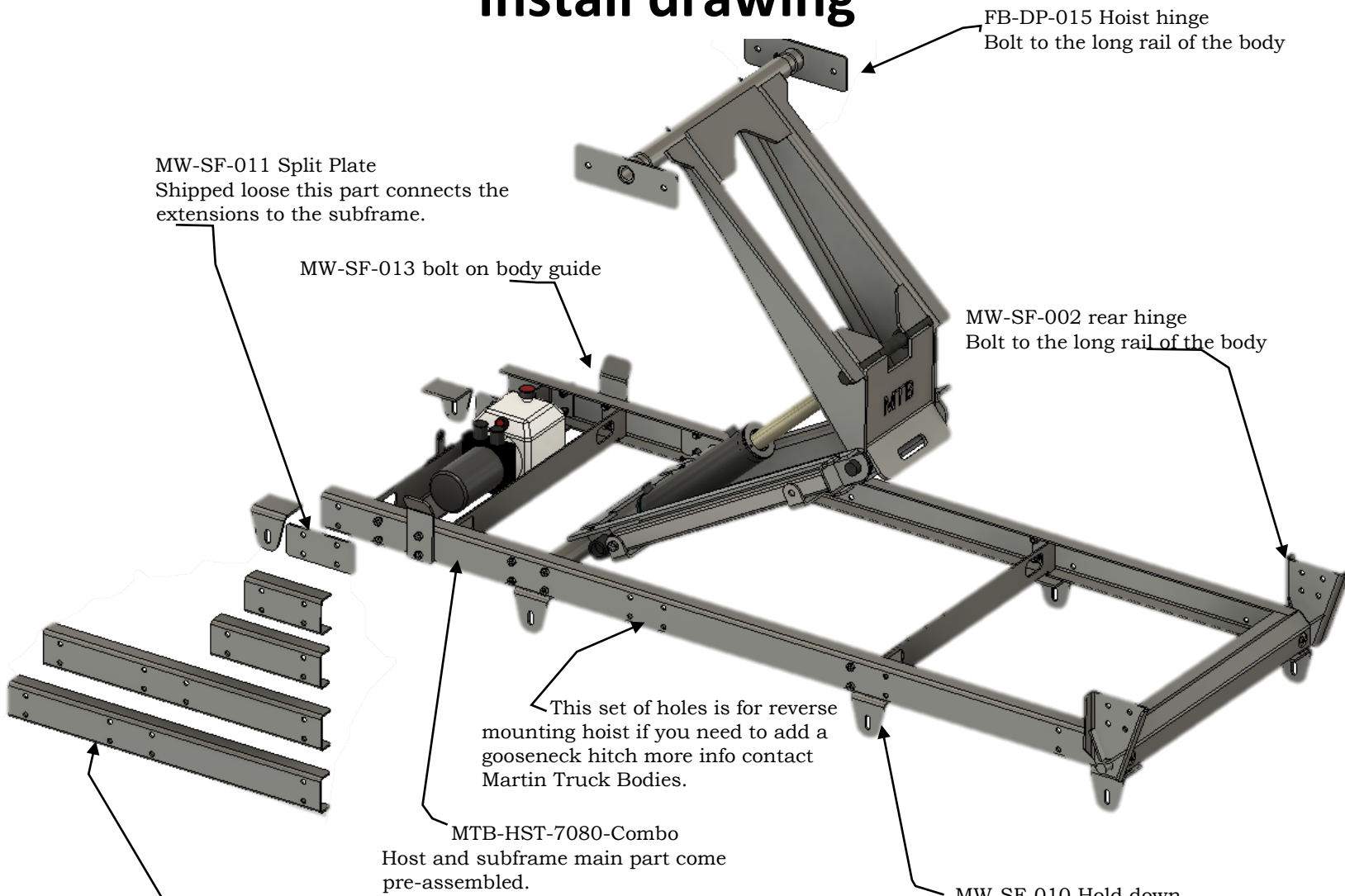

This subframe comes as a pre-assembled unit. For the different frame lengths extensions are truck specific.

Part# and info on available extensions

- MK-SF-014 10" long for 60CA ford trucks
- MK-SF-015 14" long for 60CA Ram&GM trucks
- MK-SF-016 33" long for 84CA ford trucks
- MK-SF-017 37" long for 84CA Ram&GM trucks
- MK-SF-018 48" Long
- MK-SF-019 72" long

These parts are shipped loose need welded to the martin subframe then bolted to the truck frame space approx. every 36" apart that depends were you can put them on the frame one needs to be right under the hoist pivot point. And in the back you can weld the subframe to the rear hitch instead of this bracket.

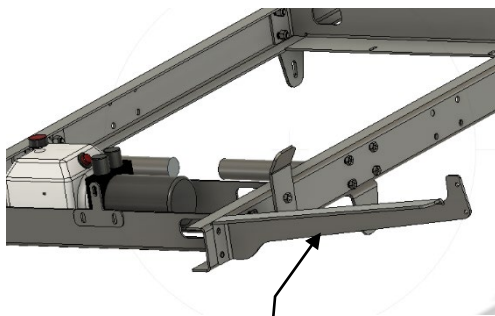

MTB-SF78-008
Bolt on fuel bracket one shipped loose with the subframe & hoist.

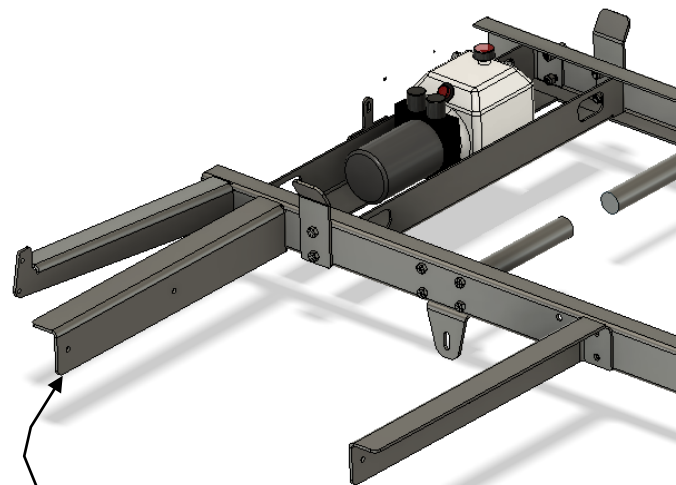

MW-SF78-005
Bolt on toolbox brackets Sold separately.

Fluid Recommendations
Do Not Mix Hydraulic Fluids.

Martin Truck Bodies Inc. recommends using a Dextron hydraulic oil to ensure optimum performance and system life. Select oil that has anti-wear properties, rust and oxidation inhibitors, foam inhibitors and good stability.

Aviation Oils such as **Valvoline ROYCO** series or **Mobil Aero HF** or **HFA** may be used in **prolonged, extreme cold** environments.

Do Not Use Biodegradable Hydraulic Fluid with Buna seal, Biodegradable Hydraulic Fluid is compatible with Viton seals (optional).

Ambient Temperature Range	ISO Viscosity Grade
- 20°F to + 32°F (- 29°C to + 0°C)	15
+ 14°F to + 120°F (- 10°C to + 49°C)	22, 32, ATF (Dexron III)

Battery Cables

To minimize voltage drop, increase the gauge size of the battery cables as the length of the positive and ground cables increases. Low voltage will cause the motor to run higher amps causing damage to other electrical components. Use 300 AMP fuse less than 18" from the battery.

Cable Length	Wire Gauge	Nominal OD (in.)
1 to 2 feet	4 gauge	0.43
3 to 4 feet	2 gauge	0.49
5 to 7 feet	1 gauge	0.56
8 to 9 feet	1/0 gauge	0.61
10 to 12 feet	2/0 gauge	0.66
13 to 15 feet	3/0 gauge	0.72
16 to 19 feet	4/0 gauge	0.78

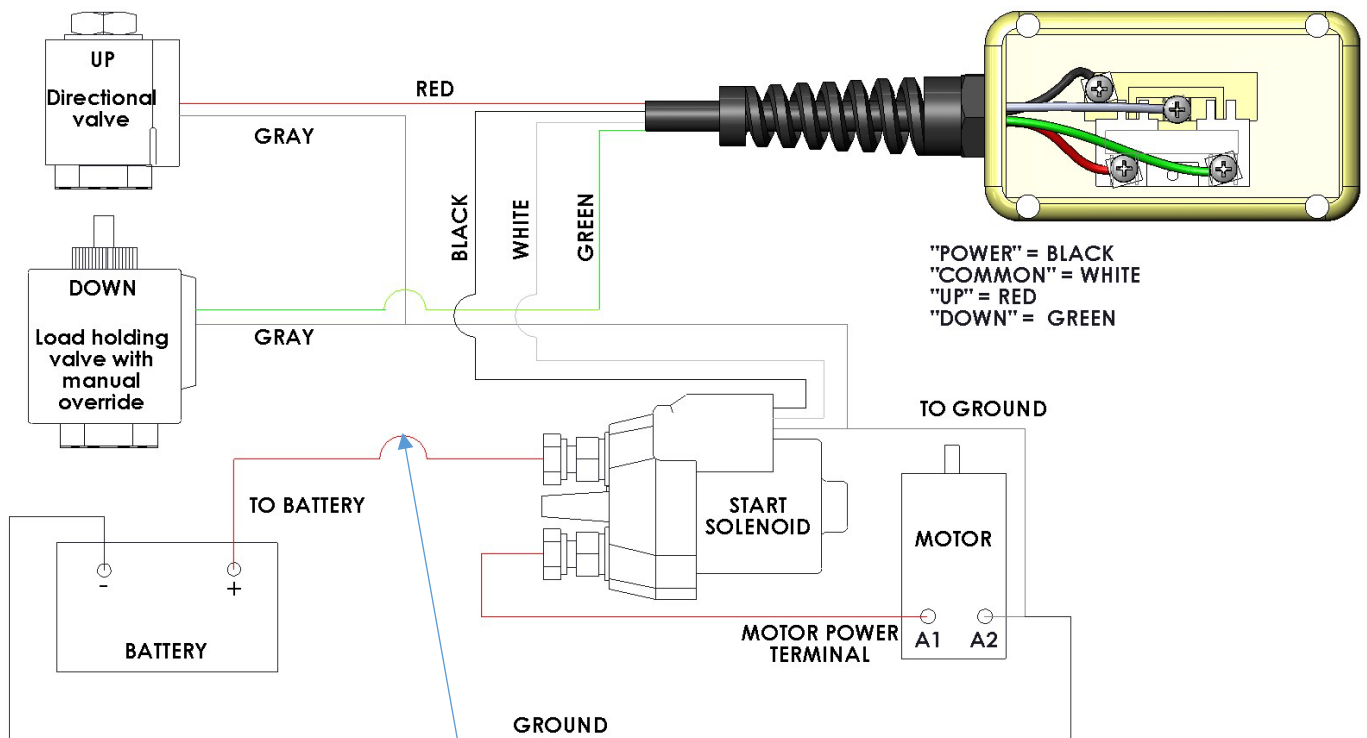

300 Amp Fuse installed before the battery.

Maintenance

1. Check the hydraulic fluid level every 6 months. If additional fluid is required add Automatic Transmission Fluid see Page 2. The fluid should not need to be changed unless it becomes contaminated from an outside source. To **check the fluid level** follow step #4 in the “Mounting and Operating Instructions”.
2. Depending on frequency of use, check all bolts for proper tightness and torque.
3. Grease all grease fittings on hoist monthly, use multipurpose lithium grease.

WARRANTY

Martin Truck Bodies warrants each Subframe & Hoist to be free of defects in material and workmanship for a period of 3-Years from the date of the initial purchase. If a defective product is found, the manufacturer is to be given a reasonable time to correct the product. Warranty repair does not include removing aftermarket accessories or items that were not part of the original product.. No Claims for warranty will be considered unless authorized by Martin Truck Bodies. No warranty will apply to:

1. Normal maintenance service or adjustments.
2. Adversely affect stability, operational characteristics or safety is in Martin truck bodies judgment, nor which has been subject to misuse, negligence, accident, poor assembly or improper installation.
3. Accessories or other items associated or used with, but which are not a part of the equipment.

No Claims for warranty will be considered unless authorized by Martin Truck Bodies.

Martin truck bodies shall not be liable or responsible in any way or to any extent for property damage, personal injury, or death resulting from the modification or alteration to the equipment or from purchaser’s failure to assemble, install, maintain, or operate the equipment in accordance with the service and/or operator’s manual.

Safety Information:

Warning: Not installing or operating equipment correctly can cause component damage or an accident which may cause injury or death. **"Always"** install and operate equipment in accordance with the manufacturer's instructions. Read and understand this manual fully before proceeding.

Warning: Welding, oxyfuel cutting, or grinding sparks can cause fuel to ignite which in turn can lead to injury or death. **"Always"** take adequate steps to avoid ignition of fuel from fuel tanks when welding, grinding, or oxyfuel cutting during equipment installation.

Warning: Heat from the truck's exhaust system can cause hydraulic component failure and may lead to a fire which could cause injury or death. **"Always"** install equipment in locations where heat from the exhaust system will not damage any hydraulic component.

Warning: Being under a raised body can result in serious injury or death should the body inadvertently descend. **"Never"** position yourself or allow others to position themselves under a "loaded" body. **"Always"** prop the "unloaded" body up using the body prop or body props supplied. **"Remember"** body props are to be used only on an "unloaded" body.

Warning: Malfunctioning equipment can cause property damage, injury or death. **"Always"** have faulty equipment repaired before continuing its use. If required, consult the manufacturer.

Warning: Overloading of a truck can cause truck component damage or an accident which may cause injury or death. **"Never"** exceed the gross vehicle weight (GVW) or the gross axle weight (GAW) rating of your vehicle. This rating can be found on the end of the driver's door just above or below the latch.

Warning: The inadvertent shorting of the truck's electrical supply can cause a fire or equipment damage that could lead to injury or death. **"Always"** disconnect the vehicle battery prior to installing, servicing or repairing the pump.

Warning: Never install a cable on a truck while the body is raised without first blocking, bracing, or propping the body up to prevent the body from inadvertently falling when the control valve lever is moved. A falling body will result in serious injury or death if the control valve lever is moved while someone is under the non-supported body.

Warning: Damage to brake lines during equipment installation or installing bolts or equipment in such a way that the line will rub and become damaged can lead to brake failure which can cause an accident and can lead to severe injury or death. **"Always"** take adequate steps to prevent brake line damage during installation and isolate brake lines from installed equipment.

Warning: To prevent damage to the truck's electrical system, disconnect the positive battery cable and alternator when arc welding on the truck.

Double Acting Hoist Operation: CAUTION: To ensure long service and safety from your hoist, it is important that the following procedure be followed every time the hoist is operated. 1. To raise the hoist, push in the control station button marked "up". This will activate the pump. 2. When the hoist has reached its full extension, the pump will bypass. Care should be taken not to allow the pump to bypass for long periods of time for this will put stress on the entire hydraulic system. To stop the pump from bypassing, release the "up" button on the control station. 3. To lower the hoist, push the control station button marked "down". This will activate the pump and start the hoist down. Hold the button down until the pump bypasses and then release this button. This will lock the truck body against the truck frame. **WARNING:** Anytime the hoist or truck body is worked on with the truck body in a raised position, be sure the unloaded body is properly blocked with the body prop or body props.